

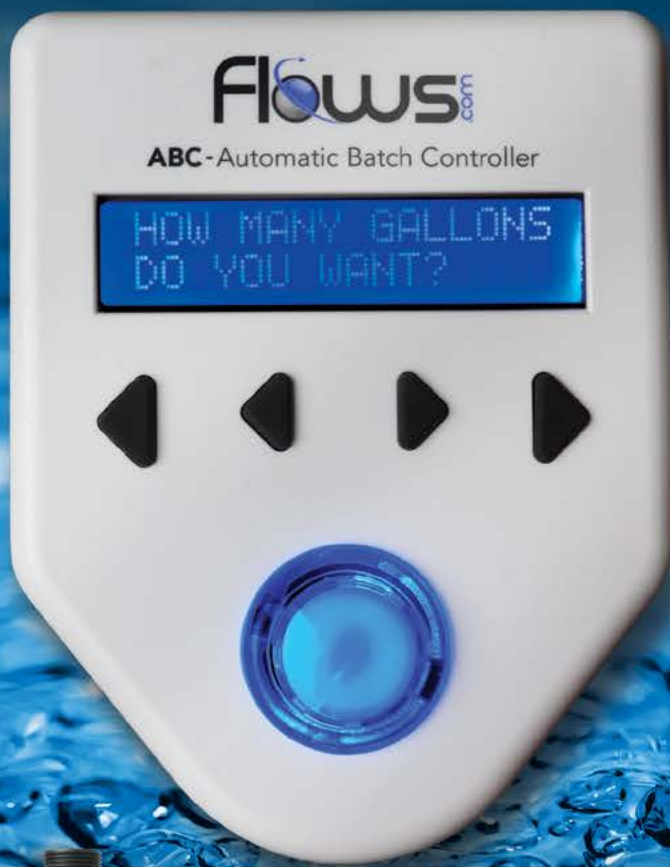

ABC-2020

Automatic Batch Controller

Simple • Versatile • Accurate • Repeatable



We Are **Water Meter** Experts

ABC Automatic Batch Controllers



Specifications

Enclosure: ABS Polycarbonate blend

Supply Voltage: 12VDC
(using transformer wall adapter that is provided)

Maximum Valve Current Draw: 2 Amps at 12VDC

Ambient Temperature: 22°F to 122°F

Maximum Pulse Rate:

One pulse per second (for use with a fast-acting valve)

One pulse per 5 seconds (for use our EBV ball valves)

*Max. pulse rate varies depending on the cycle speed of the valve being used

Accuracy:

Will match that of the meter used with a slight additional inaccuracy on the first and last unit possible depending upon system setup and conditions

Applications

- Pool and pond filling and lawn watering
- Potable water truck filling
- Commercial kitchen batching
- Brewery kettle filling
- Water based product manufacturing
- Farm, garden, and greenhouse irrigation

Features

- Works with any meter that provides a contact closure type pulse output
- Certain voltage pulse outputs can be used with the addition of a pulse converter
- Able to control any actuated valve from a simple 12VDC solenoid valve to a pneumatically actuated full port ball valve
- Can also control a pump in-place of or in addition to a valve
- Bright 16 x 2 display that is easy to read
- Various programs for the most common applications as well as custom programming available
- The Big Blinking Blue Button™ clearly indicates the status of the system and is visible from a distance
- Simple push-in connections for all wires
- Choose from 4 display modes with the simple push of a button while the batch is running
- "Batch almost complete" indication for the last 10% of the batch (can be customized)
- Ready for the addition of a remote start/stop button which can be purchased separately and mimics the indication and operation of the Big Blinking Blue Button™ from a different location
- Mounting kit included for easy installation on a wall or a horizontal or vertical pipe.

Description

The ABC Series Automatic Batch Controllers are extremely simple to operate. Use the arrow buttons to go up and down to get to your desired volume. Once the volume is set, press the **Big Blinking Blue Button™** and the batch will start (by either opening a valve or starting a pump). As the batch dispenses, the **Big Blinking Blue Button™** will blink once per second. When the final 10% of the batch is being dispensed, the speed of blinking will increase to 10 times per second. When the batch is complete, the valve closes or the pump shuts off and the **Big Blinking Blue Button™** will remain lit, indicating that the unit is ready to dispense the next batch. The volume set will be the same as it was for the batch just run, but can easily be changed again by using the arrow buttons.

ABC Automatic Batch Controllers

The Controller

Physical Features

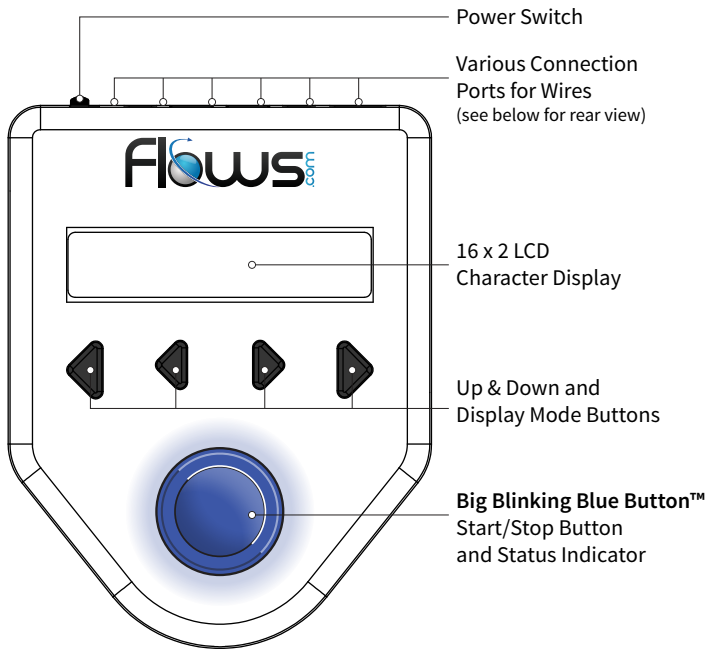

Wires & Connections

Back of Controller

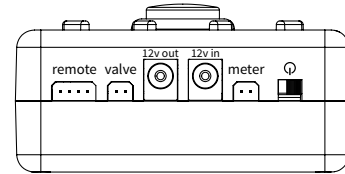

The connection ports in the back of the controller are clearly labeled. When ordered with valve and meter, those come with the proper connector on the wire to simply plug in to the controller. For use with meters and valves purchased elsewhere separately, wiring connector kits are available. Call 1-855-871-6091 to order a wiring connector kit.

Mounting Kit (included)

Wall/Pipe Mounting Plate

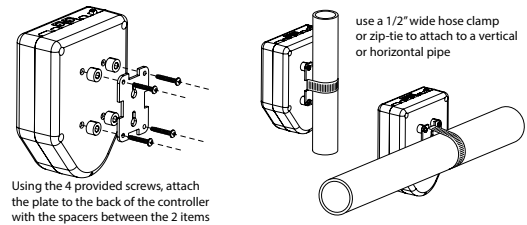

Basic System Setups

Using a Valve

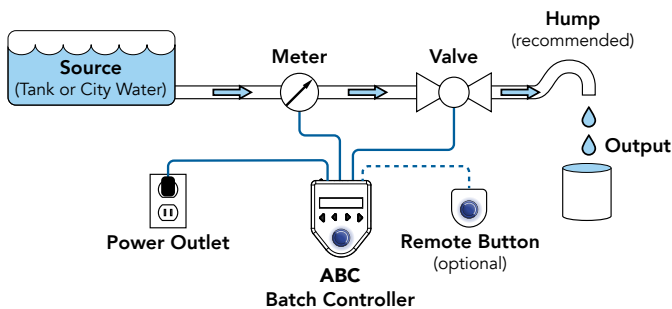

Valves are used in situations where the liquid already has a method of transfer. That can be city water pressure, a pressurized tank, or gravity feed. We recommend placing the valve AFTER the meter. A valve can also be used in conjunction with a continuously running pump, as long as that pump can be dead-headed. It is important to note that in a gravity feed system, the flow rate will decrease as the tank level is reduced.

Using a Pump

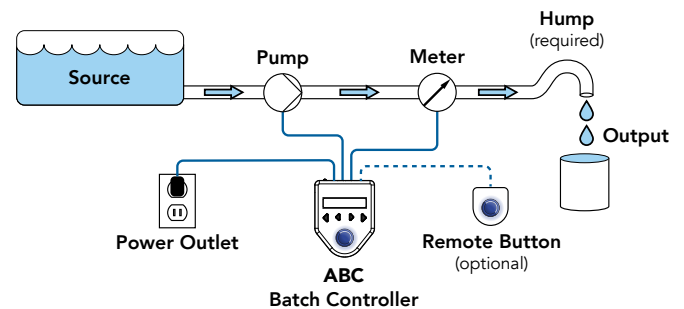

Pumps are used in place of a valve when there is no method of liquid transfer present. The pump should be placed BEFORE the meter, and the plumbing after the meter must be such that the liquid will not drain out of the meter when the batch is complete. Placing a simple hump in the line that is higher than the meter near the outlet accomplishes this. It is also important to select a pump that will not allow fluid to siphon through it, otherwise, the outlet must also be higher than the level of the liquid in the supply tank.

ABC Automatic Batch Controllers

Meters

Multi-Jet Water Meters

There are 3 series of Multi-Jet meters available. They are exactly the same with the exception of the materials that they are constructed of.

These meters, due to the working principle, must be installed horizontally with the register (face) facing directly upwards.



WM-PC Series

Glass Reinforced Plastic
NPT male threaded connections w/ union
(1/2" to 1 1/2")



WM-NLC Series

Lead free brass
NPT male threaded connections w/ union
(1/2" to 2")



WM-NLCH Series

Lead free brass for HOT water
NPT male threaded connections w/ union
(1/2" to 2")

Positive Displacement Water Meters

Positive displacement meters can be installed in any orientation. The working principle in these meters makes it impossible for liquid to pass through without being measured.



D10-NSF Series

Lead free brass
NPT male threaded connections
w/ union (1/2" to 1")
2-bolt oval flange connections
(1 1/2" to 2")

NSF/ANSI Certification



NSF International

All of the valves and meters listed on this page are NSF approved, and are suitable for use in applications where they come in direct contact with ingredients intended for human consumption.

Certified to
NSF/ANSI 61-G

Valves

Electric Solenoid Valves

Solenoid valves are fast acting, normally closed valves. They operate using an electromagnetic coil that retracts a plunger when energized. They are well suited for smaller batches and faster pulse rates like 10 pulses per gallon where a fast shut-off is required to avoid dispensing a complete unit after the valve closure is triggered by the controller.



ESV Series

Stainless steel with Viton® seals
NPT female threaded connections
1/4" to 2"
12VDC (powered by controller directly)
Normally closed

Many other solenoid valves are available, this is simply the most common, and what we recommend for general purpose applications including those with food grade requirements. Call for information on other solenoid valve types.

Electric Ball Valves

Ball valves offer higher flow rates than solenoid valves when used in equivalent conditions. They are full port which means there is no restriction of flow. They are recommended for larger batches with slower pulse rates. They have a 3-5 second cycle time for opening and closing. This means that the pulse rate should be no greater than 6 seconds, which would be 1 pulse per gallon at 10 gallons per minute.



EBV Series

Stainless Steel with Viton® Seals
NPT female threaded connections
1/4" to 2"
12VDC (powered by controller directly)
Normally closed
Capacitive return to closed

Many other ball valves are available including air-operated which are much faster acting. Our partner, **Assured Automation**, offers a complete range of actuated ball valves with solutions for any application.

Pumps

120VAC Pump Relay

This simple powerstrip with relay controlled outlets makes it extremely easy to use the ABC controller to control a pump or 120VAC valve

ABC Automatic Batch Controllers

Model Code for Complete Systems

ABC-2020-1-NLC-EBV-075

Automatic Batch Controller

Standard Programs (custom programming available)

- 20** = 20ths of a gallon (20 pulses per gallon)
- 10** = 10ths of a gallon (10 pulses per gallon)
- 1** = Whole gallons (1 pulse per gallon)
- 1X** = Whole gallons (1 pulse per gallon) with Lockout
- 10G** = 10 gallons (1 pulse per 10 gallons)
- 10X** = 10 gallons (1 pulse per 10 gallons) with Lockout

Meter Type

- PC** = WM-PC Plastic Multi-Jet water meter
- PD** = WM-PD Plastic Positive Displacement water meter (20 pulses per gallon only)
- NLC** = WM-NLC Lead Free Brass Multi-Jet water meter
- NLCH** = WM-NLCH Lead Free Brass Multi-Jet HOT water meter
- D10** = D10-NSF Lead Free Brass Positive Displacement water meter

Note: Many other meter types are available

Valve Type or Pump Relay

- EBV** = Electric Ball Valve
 - ESV** = Electric Solenoid Valve
 - PR** = 120VAC pump relay
- Note:** Many other valve types available including pneumatically operated (air driven)

Line Size (both meter and valve)

- 050** = 1/2" NPT
- 075** = 3/4" NPT
- 100** = 1" NPT
- 150** = 1 1/2" NPT
- 200** = 2" NPT

Accessories



NEMA 4X Weatherproof Enclosure

For using the ABC Batch Controller outdoors or in washdown environments.

Part Number: ABC-NEMA-BOX



NEMA 4X Weatherproof Remote Button

For remote start/stop of batches as well as batch status indication.

Part Number: ABC-REM-BUT-WP

Pulse Converter

For use with meters that provide a voltage pulse output rather than a contact closure.

Extension Wires

For the simple extension of meter and valve wires without any cutting, soldering, or splicing.

3-way Valves

Used to select one of two outlets for dispensing. This allows a single batch control setup to be used on two separate lines. Also can be used to create a bypass line that is independent from the valve and meter.