

## SO Series

### Use & Care Manual

#### 1. INSTALLATION

1. Determine if accessory mounting holes on top of actuator have 80 mm pattern or 130 mm pattern. For actuators with 80 mm accessory mounting hole pattern the SM/SP Series limit switch mounting legs should be pointing towards the actuator drive shaft. For actuators with 130 mm accessory mounting hole pattern the mounting legs should be inverted such that they are pointing away from the actuator drive shaft. After the correct mounting pattern has been selected, the limit switch mounting legs must be loosely fastened to the actuator using four 10-24 x 3/4" socket head setscrews, lock washers and nuts.
2. Align switch box shaft to top of actuator shaft while simultaneously aligning the limit switch mounting legs with the appropriate slots in the limit switch housing. Carefully lower the limit switch housing and engage the limit switch shaft with the actuator shaft.
3. Secure the limit switch housing to the mounting legs using the M5 (11) socket head caps screws provided.
4. Rotate the actuator several times to allow the limit switch and actuator to self-align with each other.



5. Tighten the mounting leg fasteners to secure the mounting legs to the top of the actuator.

#### 2. SWITCH ADJUSTMENT

1. Loosen switch box cover screws (22) and remove cover (20).
2. Remove indicator pointer (42) by grasping firmly and lifting up. This will disengage the cams from the locking teeth on the drive shaft.
3. Rotate the actuator counter-clockwise.
4. Rotate the bottom cam until switch is activated.
5. Rotate the actuator clockwise.
6. Rotate the top cam until switch is activated.

- Set pointer indicator (42) to match valve position (i.e. perpendicular for closed, parallel for open). Re-insert pointer indicator into the limit switch drive shaft. This will cause the drive shaft to flair open and lock the cams in position.
- Place cover (20) on switch box and tighten. Take care to ensure that cover gasket seal is properly located in seal groove.

### 3. ELECTRICAL WIRING

- Remove switch box cover (20).
- Engage field wires in terminal strip (33) using a small screwdriver (1/8" blade). Re-install switch box cover (20).

### PARTS DIAGRAM

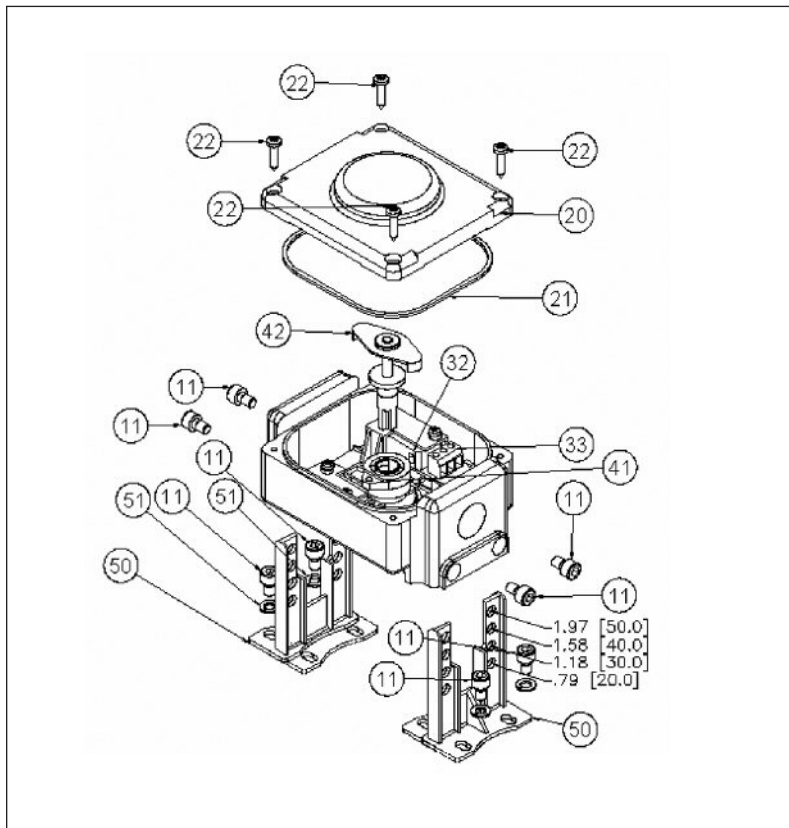

### MOUNTING HOLE SCHEMATIC

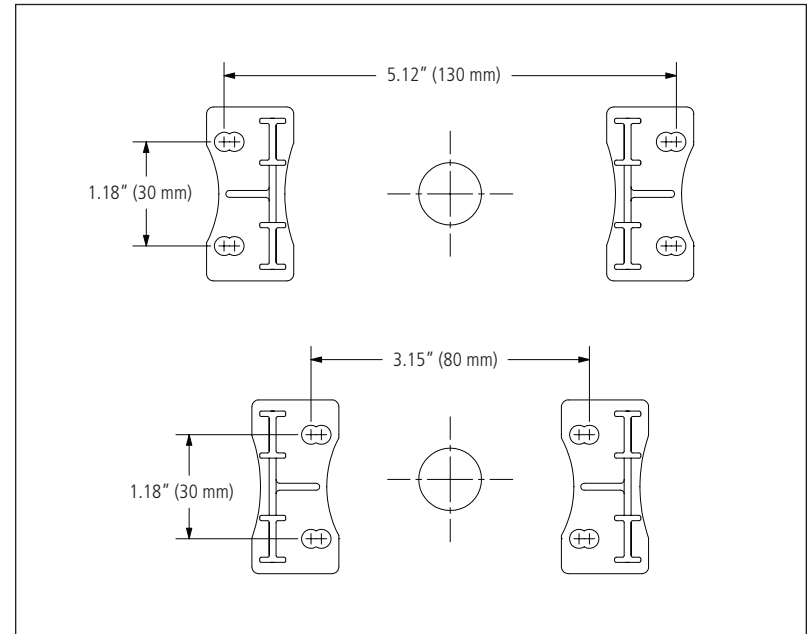

### WIRING SCHEMATIC

