

ASSURED AUTOMATION

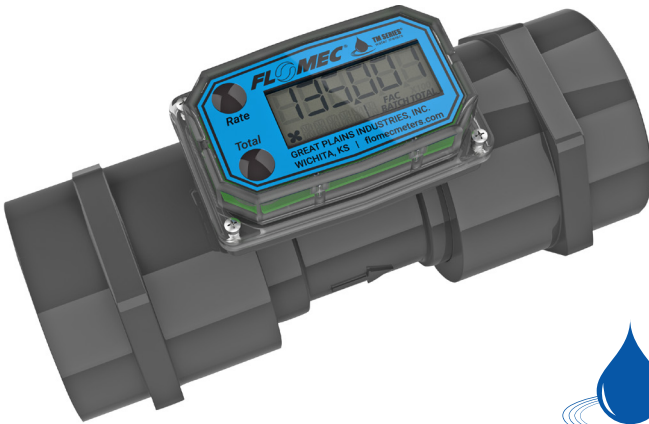

TM SERIES[®]
water meters



TM Series[®] Electronic Water Flowmeters

1/2 INCH - 2 INCH METER SIZES
[TM05XXXXXX - TM20XXXXXX MODELS]

For 3 inch and 4 inch Models see page 13



Please save these instructions for future reference. Read carefully before attempting to assemble, install, operate or maintain the product described.

Protect yourself and others by observing all safety information. Failure to comply with instructions could result in personal injury and/or property damage.

Please refer to back cover for information regarding this product's warranty and other important information.

DO NOT RETURN THIS PRODUCT TO THE STORE!

Please contact Great Plains Industries, Inc.® before returning any product. If you are missing parts, or experience problems with your installation, contact our Customer Support Department. We will be happy to assist you.

Call: 888-996-3837 or 316-686-7361

Email: meters@tplains.com

SAVE FOR YOUR RECORDS

Model #: _____

Serial #: _____

Purch. Date: _____

BEFORE YOU BEGIN

Usage Requirements

- Use TM Series meters with water and other chemicals compatible with wetted components.
- **DO NOT** use to meter fuel or incompatible chemicals.
- TM Series meters are very sensitive to electric noise if operated within 1 to 2 inches of some electric motors or other sources of electronic noise.
- This meter is not legal for trade applications.

UNPACKING/INSPECTION

Inspect

- After unpacking the unit, inspect carefully for any damage that may have occurred during transit. Check for loose, missing or damaged parts. Shipping damage claims must be filed with carrier.
- See General Safety Instructions, and all Cautions, Warnings, and Dangers as shown.



GENERAL SAFETY INSTRUCTIONS

IMPORTANT: It is your responsibility to:

- Ensure that all equipment operators have access to adequate instructions concerning safe operating and maintenance procedures.

▲ WARNING

Compatibility of this product's material and the process fluid and/or environment should be considered prior to putting into service.

▲ WARNING

Product should never be operated outside its published specifications for temperature or pressure. See specifications for your model.

▲ WARNING

Make sure flow and pressure have been eliminated from process pipe prior to installing or removing product.

▲ WARNING

Always use appropriate thread sealant or flange gaskets when connecting product to process piping.

▲ CAUTION

To protect against leakage, seal all pipe threads with an appropriate sealing compound. Make sure the sealing compound does not intrude into the flow path.

NOTE: If connecting to new male pipe threads, burrs and curls can adversely affect accuracy. Correct the problem prior to turbine installation.

▲ CAUTION

Installation near high electromagnetic fields and high current fields is not recommended and may result in inaccurate readings.

SPECIFICATIONS



GETTING STARTED

SAFETY / SPECIFICATIONS

ASSEMBLY / INSTALLATION

OPERATION / CALIBRATION

MAINTENANCE / REPAIR

	TM05 - 1/2 INCH	TM07 - 3/4 INCH	TM10 - 1 INCH	TM15 - 1-1/2 INCH	TM20 - 2 INCH
Type	Turbine Flowmeter				
Unit of Measure	Gallon or Litre				
Flow Range	1-10 GPM 3.8-38 L/min	2-20 GPM 7.6-76 L/min	5-50 GPM 19-190 L/min	10-100 GPM 38-380 L/min	20-200 GPM 76-760 L/min
Accuracy w/ Computer	+/- 3.0% of Reading (Accuracy can be improved with field calibration)				
Max. Working Pressure	225 PSIG @ 73°F (15.5 bar @ 23°C); BSP - 150 PSIG @ 73°F (10.3 bar @ 23°C)				
Operating Temperature	+32°F to +140°F (0°C to +60°C) - Do not allow fluid to freeze inside meter				
Storage Temperature	-40°F to +140°F (-40°C to +60°C)				
Field Calibration	Yes				
Wetted Components	Housing: PVC Journal bearings: Ceramic Shaft: Tungsten carbide Rotor and supports: PVDF Retaining washer: Stainless steel				

Inlet / Outlet Connections

	TM05	TM07	TM10	TM15	TM20
S - (SPIGOT)	1/2 inch Schd. 80	3/4 inch Schd. 80	1 inch Schd. 80	1-1/2 inch Schd. 80	2 inch Schd. 80
N - (NPT)	1/2 inch NPT	3/4 inch NPT	1 inch NPT	1-1/2 inch NPT	2 inch NPT
B - (BSP)	N/A	N/A	1 inch BSP	1-1/2 inch BSP	2 inch BSP

Weight

	TM05	TM07	TM10	TM15	TM20
S - (SPIGOT)	0.38 lbs. (0.172kg)	0.43 lbs. (0.195kg)	0.49 lbs. (0.222kg)	0.66 lbs. (0.299kg)	0.78 lbs. (0.354kg)
N - (NPT)	0.55 lbs. (0.249kg)	0.67 lbs. (0.304kg)	0.84 lbs. (0.381kg)	1.38 lbs. (0.628kg)	1.78 lbs. (0.807kg)
B - (BSP)	N/A	N/A	0.84 lbs. (0.381kg)	1.47 lbs. (0.666kg)	1.93 lbs. (0.875kg)

Weight shown is with computer display. Output modules add 0.30 lbs/0.14 kg

SPECIFICATIONS (CONTINUED)

TM Meter Size & Fitting	Length (A)	Height (B)	Width (C)
Dimensions			
TM05S - Spigot	4.3 in. (109 mm)	2.5 in. (63 mm)	2.1 in. (53 mm)
TM05N - NPT	6.0 in. (152 mm)	2.7 in. (68 mm)	2.1 in. (53 mm)
TM07S - Spigot	4.4 in. (112 mm)	2.7 in. (68 mm)	2.1 in. (53 mm)
TM07N - NPT	6.1 in. (155 mm)	2.9 in. (73 mm)	2.1 in. (53 mm)
TM10S - Spigot	4.5 in. (114 mm)	2.9 in. (73 mm)	2.1 in. (53 mm)
TM10N - NPT	6.5 in. (165 mm)	3.1 in. (79 mm)	2.1 in. (53 mm)
TM10B - BSP	6.7 in. (170 mm)	3.1 in. (79 mm)	2.1 in. (53 mm)
TM15S - Spigot	5.4 in. (137 mm)	3.6 in. (91 mm)	2.1 in. (53 mm)
TM15N - NPT	7.6 in. (193 mm)	3.8 in. (96 mm)	2.3 in. (58 mm)
TM15B - BSP	7.6 in. (193 mm)	3.7 in. (94 mm)	2.2 in. (56 mm)
TM20S - Spigot	5.5 in. (140 mm)	4.1 in. (104 mm)	2.4 in. (61 mm)
TM20N - NPT	7.9 in. (200 mm)	4.4 in. (112 mm)	3.5 in. (89 mm)
TM20B - BSP	7.8 in. (198 mm)	4.2 in. (107 mm)	2.7 in. (69 mm)

Length guidelines are estimates; actual length can vary up to $\pm \frac{1}{2}$ in. (13 mm).

Output modules add 0.90 in. (23 mm) to height.

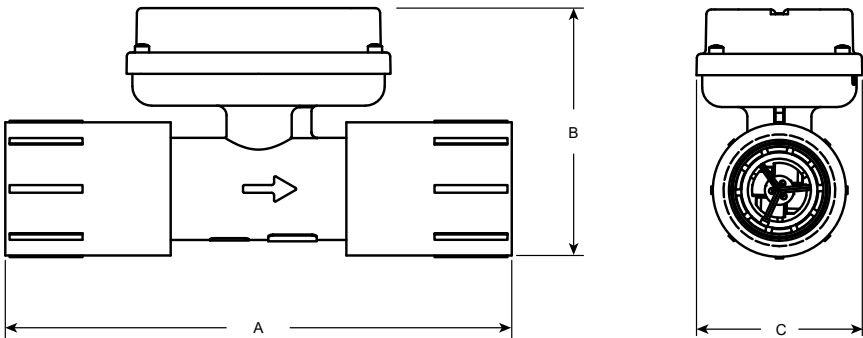

INSTALLATION

IMPORTANT: TM Series meters are available with either a computer for local electronic display, or three versions of output modules (see [PARTS](#) section of this manual) to provide a digital signal to customer interfacing equipment. TM Series meters with computer display ship pre-configured from the factory in either gallons or liters. The volume unit can be changed to several other options. Refer to the Q9 owner's manual for details on changing or customizing the volume unit.

Connections

Install your meter in-line either horizontally or vertically. Installation to metal connections is not recommended. Install as follows:

- Plan to install turbine with a minimum straight pipe length as follows (see Figure 2):
 - Upstream from the turbine, allow a minimum straight pipe length of 10 times the internal diameter of the turbine.
 - Downstream from the turbine, allow a minimum straight pipe length of 5 times the internal diameter of the turbine.
- For Spigot (Pipe) End use only primer and solvents approved for PVC gluing.

For NPT and BSP Fittings wrap all connections with 3 to 4 wraps of thread tape (optional to use pipe thread sealant). Make sure the tape does not intrude into the flow path.

- Attach meter with arrow pointed in the direction of fluid flow.
- For NPT and BSP Fittings - Hand tighten the meter at the housing ends. Do not use a wrench or similar tool to tighten. This can damage the housing.

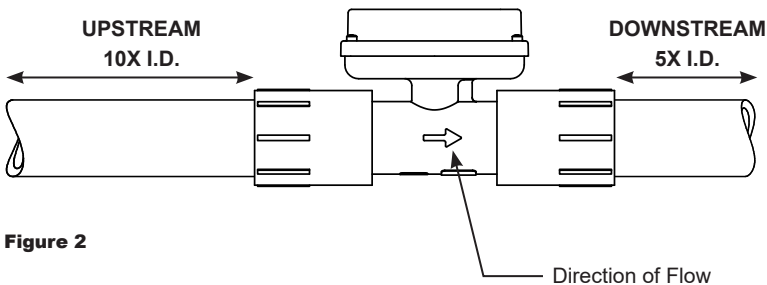

Figure 2

Verify Meter Accuracy

Before using, check the meter's accuracy and verify calibration.

1. Make sure there is no air in the system by starting the flow until it runs steadily. Then, stop or divert the flow using a valve or nozzle
2. Meter an exact known volume into an accurate container. For best results, meter with one continuous full stream.
3. Check the volume against the display or recording equipment. If the amount metered is accurate, further calibration is not necessary. If not, refer to the Q9 Owner's Manual (Non-Agency) Field Calibration Section for further instructions (see below).

NOTE: Make sure you meet the meter's minimum flowrate requirements:

TM Series Meter Minimum Flowrate

TM05 - 1/2 inch	1 GPM (3.8 L/min)
TM07 - 3/4 inch	2 GPM (7.5 L/min)
TM10 - 1 inch	5 GPM (18.8 L/min)
TM15 - 1-1/2 inch	10 GPM (37.5 L/min)
TM20 - 2 inch	20 GPM (75 L/min)

You can download the Q9 Owner's Manual (Non-Agency) here:



or visit FLOMECmeters.com to download owner's manuals and other technical documents.

MAINTENANCE

NOTE: Proper handling and care will extend the life and service of the meter

Turbine Rotor

The meter is virtually maintenance-free. However, it is important the rotor moves freely. Keep the meter clean and free of contaminants.

If the rotor does not turn freely, apply a penetrating lubricant on the rotor, shaft and bearings. Remove any debris or deposits from the rotor using a soft brush or small probe. Be careful not to damage the turbine rotor or supports.

▲ CAUTION

Blowing compressed air through the turbine assembly could damage the rotor.

▲ CAUTION

Do not allow liquids to dry inside the turbine.

▲ CAUTION

Handle the rotor carefully. Small scratches or nicks can affect accuracy.

Part Number	Description
116000-1	Calibration container, Large (5 gallon)
901002-52	Seal
113435-10	Conditioned Signal Module (GEN 2)
125060-10	Pulse Access/External Power/Scaled Module (GEN 2)
125100-10	4-20mA Module

PARTS & SERVICE

For warranty consideration, parts, or other service information, please contact your local distributor. If you need further assistance, contact the GPI Product Support Department in Wichita, Kansas, during normal business hours.

A toll free number is provided for your convenience.

1-888-996-3837

To obtain prompt, efficient service, always be prepared with the following information:

- The model number of your meter.
- The serial number or manufacturing date code of your meter.
- Part descriptions and numbers.

For warranty work, always be prepared with your original sales slip or other evidence of purchase date.

IMPORTANT: Please contact GPI before returning any parts. It may be possible to diagnose the trouble and identify needed parts in a telephone call.

CAUTION

Do not return this product without prior approval from the GPI Product Support Department. Due to strict government regulations, GPI cannot accept parts unless they have been drained and cleaned.

WEEE DIRECTIVE



The Waste Electrical and Electronic Equipment (WEEE) directive (2002/96/EC) was approved by the European Parliament and the Council of the European Union in 2003. This symbol

indicates that this product contains electrical and electronic equipment that may include batteries, printed circuit boards, liquid crystal displays or other components that may be subject to local disposal regulations at your location. Please understand those regulations and dispose of this product in a responsible manner.

ROHS COMPLIANT (2011/65/EU)

This product is in compliance with the RoHS Directive of the European Parliament and of the Council on the Restriction of the Use of Certain Hazardous Substances in Electrical and Electronic Equipment.

Environmental Rating: IP65

FLOMEC® TWO-YEAR LIMITED WARRANTY

Great Plains Industries, Inc. 5252 E. 36th Street North, Wichita, KS USA 67220-3205, hereby provides a limited warranty against defects in material and workmanship on all products manufactured by Great Plains Industries, Inc. This product includes a 2 year warranty. Manufacturer's sole obligation under the foregoing warranties will be limited to either, at Manufacturer's option, replacing or repairing defective Goods (subject to limitations hereinafter provided) or refunding the purchase price for such Goods theretofore paid by the Buyer, and Buyer's exclusive remedy for breach of any such warranties will be enforcement of such obligations of Manufacturer. The warranty shall extend to the purchaser of this product and to any person to whom such product is transferred during the warranty period.

The warranty period shall begin on the date of manufacture or on the date of purchase with an original sales receipt. This warranty shall not apply if:

- A. the product has been altered or modified outside the warrantor's duly appointed representative;

- B. the product has been subjected to neglect, misuse, abuse or damage or has been installed or operated other than in accordance with the manufacturer's operating instructions.

To make a claim against this warranty, contact the GPI Customer Service Department at

316-686-7361 or 888-996-3837.

Or by mail at:

Great Plains Industries, Inc.

5252 E. 36th St. North

Wichita, KS, USA 67220-3205

The company will step you through a product troubleshooting process to determine appropriate corrective actions.

GREAT PLAINS INDUSTRIES, INC., EXCLUDES LIABILITY UNDER THIS WARRANTY FOR DIRECT, INDIRECT, INCIDENTAL AND CONSEQUENTIAL DAMAGES INCURRED IN THE USE OR LOSS OF USE OF THE PRODUCT WARRANTED HEREUNDER.

The company herewith expressly disclaims any warranty of merchantability or fitness for any particular purpose other than for which it was designed.

This warranty gives you specific rights and you may also have other rights which vary from U.S. state to U.S. state.

Note: In compliance with MAGNUSON MOSS CONSUMER WARRANTY ACT – Part 702 (governs the resale availability of the warranty terms).

IP65



ASSURED
AUTOMATION

1-800-899-0553

ASSURED AUTOMATION

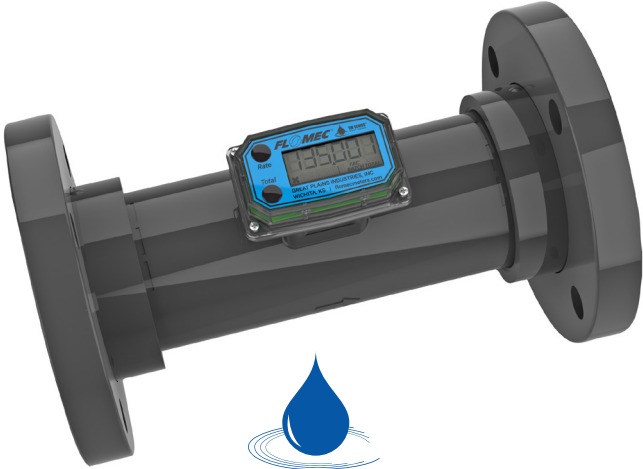

TM SERIES®
water meters



TM Series® Electronic Water Flowmeters

3 INCH & 4 INCH METER SIZES
[TM30XXXXXX - TM40XXXXXX MODELS]

Please save these instructions for future reference. Read carefully before attempting to assemble, install, operate or maintain the product described.

Protect yourself and others by observing all safety information. Failure to comply with instructions could result in personal injury and/or property damage.

Please refer to back cover for information regarding this product's warranty and other important information.

DO NOT RETURN THIS PRODUCT TO THE STORE!

Please contact Great Plains Industries, Inc.® before returning any product. If you are missing parts, or experience problems with your installation, contact our Customer Support Department. We will be happy to assist you.

Call: 888-996-3837 or 316-686-7361

Email: meters@tplains.com

SAVE FOR YOUR RECORDS

Model #: _____

Serial #: _____

Purch. Date: _____

BEFORE YOU BEGIN

Usage Requirements

- Use TM Series meters with water and other chemicals compatible with wetted components.
- **DO NOT** use to meter fuel or incompatible chemicals.
- TM Series meters are very sensitive to electric noise if operated within 1 to 2 inches of some electric motors or other sources of electronic noise.
- This meter is not legal for trade applications.

UNPACKING/INSPECTION

Inspect

- After unpacking the unit, inspect carefully for any damage that may have occurred during transit. Check for loose, missing or damaged parts. Shipping damage claims must be filed with carrier.
- See General Safety Instructions, and all Cautions, Warnings, and Dangers as shown.



GENERAL SAFETY INSTRUCTIONS

IMPORTANT: It is your responsibility to:

- Ensure that all equipment operators have access to adequate instructions concerning safe operating and maintenance procedures.

▲ WARNING

Compatibility of this product's material and the process fluid and/or environment should be considered prior to putting into service.

▲ WARNING

Product should never be operated outside its published specifications for temperature or pressure. See specifications for your model.

▲ WARNING

Make sure flow and pressure have been eliminated from process pipe prior to installing or removing product.

▲ WARNING

Always use appropriate thread sealant or flange gaskets when connecting product to process piping.

▲ CAUTION

To protect against leakage, seal all pipe threads with an appropriate sealing compound. Make sure the sealing compound does not intrude into the flow path.

NOTE: If connecting to new male pipe threads, burrs and curls can adversely affect accuracy. Correct the problem prior to turbine installation.

NOTE: Do not over tighten the flange bolts. This may cause the gasket to be compressed into the flow stream and may decrease the accuracy of the meter.

▲ CAUTION

Installation near high electromagnetic fields and high current fields is not recommended and may result in inaccurate readings.

SPECIFICATIONS

	TM30 - 3 INCH	TM40 - 4 INCH
Type	Turbine Flowmeter	
Unit of Measure	Gallon or Litre	
Flow Range	40-400 GPM 151-1514 L/min Accuracy: ± 3.0% of Reading	60-600 GPM 227-2271 L/min Accuracy: ± 3.0% of Reading
	30-600 GPM 113-2271 L/min Accuracy: ± 2.0% Full scale	40-800 GPM 151-3028 L/min Accuracy: ± 2.0% Full scale
Accuracy w/ Computer	+/- 3.0% of Reading (Accuracy can be improved with field calibration)	
Max. Working Pressure	Non-CE Applications: 225 PSIG @ 73°F (15.5 bar @ 23°C); CE Applications: 135 PSIG @ 73°F (9.3 bar @ 23°C)	
Operating Temperature	+32°F to +140°F (0°C to +60°C) - Do not allow fluid to freeze inside meter	
Storage Temperature	-40°F to +158°F (-40°C to +70°C)	
Field Calibration	Yes	
Wetted Components	Housing: PVC Journal bearings: PEEK Shaft: Stainless steel Rotor and nose cone: Acetal Washers: Stainless steel	
Inlet / Outlet Connections		
	TM30	TM40
S - (SPIGOT)	3 inch Schd. 80	4 inch Schd. 80
N - (NPT)	3 inch NPT	4 inch NPT
A - (ANSI FLANGE)	3 inch ANSI Flange	4 inch ANSI Flange
D - (DIN FLANGE)	3 inch DIN Flange	4 inch DIN Flange
Weight		
S - (SPIGOT)	2.4 lbs. (1.09kg)	3.7 lbs. (1.68kg)
N - (NPT)	3.9 lbs. (1.77kg)	6.1 lbs. (2.77kg)
A - (ANSI FLANGE)	5.8 lbs. (2.63kg)	9.2 lbs. (4.17kg)
D - (DIN FLANGE)	6.5 lbs. (2.95kg)	8.8 lbs. (3.99kg)
<i>Weight shown is with computer display. Output modules add 0.30 lbs/0.14 kg</i>		

SPECIFICATIONS (CONTINUED)

TM Meter Size & Fitting	Length (A)	Height (B)	Width (C)
Dimensions			
TM30S - Spigot	11.5 in. (292 mm)	5.34 in. (136 mm)	3.5 in. (89 mm)
TM30N - NPT	14.7 in. (373 mm)	5.78 in. (147 mm)	4.37 in. (111 mm)
TM30F ANSI Flange	12.0 in. (305 mm)	7.5 in. (190 mm)	7.5 in. (190 mm)
TM30D - DIN Flange	12.0 in. (305 mm)	8.0 in. (203 mm)	8.0 in. (203 mm)
TM40S - Spigot	13.5 in. (343 mm)	6.34 in. (161 mm)	4.5 in. (114 mm)
TM40N - NPT	17.0 in. (432 mm)	6.7 in. (170 mm)	5.87 in. (149 mm)
TM40F - ANSI Flange	14.0 in. (356 mm)	9.0 in. (229 mm)	9.0 in. (229 mm)
TM40D - DIN Flange	14.0 in. (356 mm)	8.5 in. (216 mm)	8.5 in. (216 mm)

Length guidelines are estimates; actual length can vary up to $\pm \frac{1}{2}$ in. (13 mm).

Output modules add 0.90 in. (23 mm) to height.

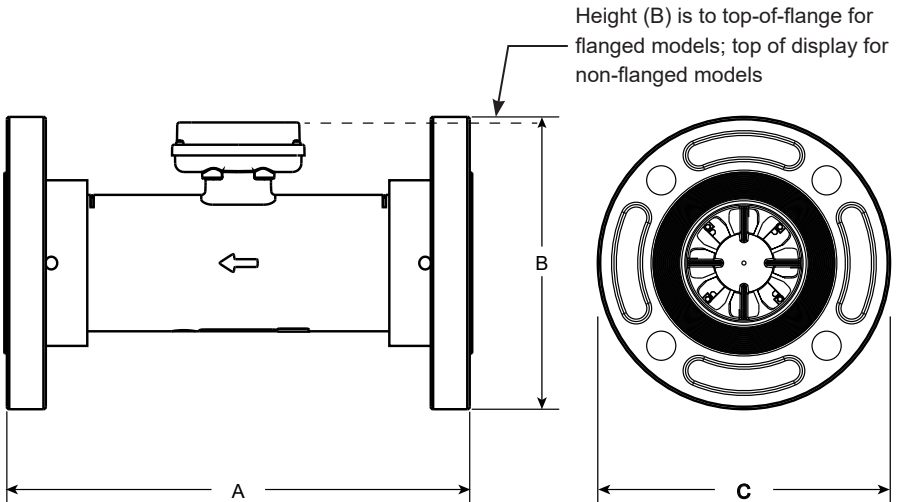

Figure 1

INSTALLATION

IMPORTANT: TM Series meters are available with either a computer for local electronic display, or three versions of output modules (see [PARTS](#) section of this manual) to provide a digital signal to customer interfacing equipment. TM Series meters with computer display ship pre-configured from the factory in either gallons or liters. The volume unit can be changed to several other options. Refer to the Q9 owner's manual for details on changing or customizing the volume unit.

Connections

Install your meter in-line either horizontally or vertically. Installation to metal connections is not recommended. Install as follows:

1. Plan to install turbine with a minimum straight pipe length as follows (see Figure 2):
 - Upstream from the turbine, allow a minimum straight pipe length of 10 times the internal diameter of the turbine.
 - Downstream from the turbine, allow a minimum straight pipe length of 5 times the internal diameter of the turbine.
2. For Spigot (Pipe) End use only primer and solvents approved for PVC gluing.

Cut to Length The meter housing can be shortened by the customer. Each meter has a "dotted" line feature molded on the top surface of the housing tube. The housing can be cut up to this line without harming any internals. Most glue on fittings will fit without interfering with the computer display area. However, the customer should check all parts before attempting cut.

For NPT and BSP Fittings wrap all connections with 3 to 4 wraps of thread tape (optional to use pipe thread sealant). Make sure the tape does not intrude into the flow path.

3. Attach meter with arrow pointed in the direction of fluid flow.
4. For NPT Fittings - Hand tighten the meter at the housing ends. Do not use a wrench or similar tool to tighten. This can damage the housing.

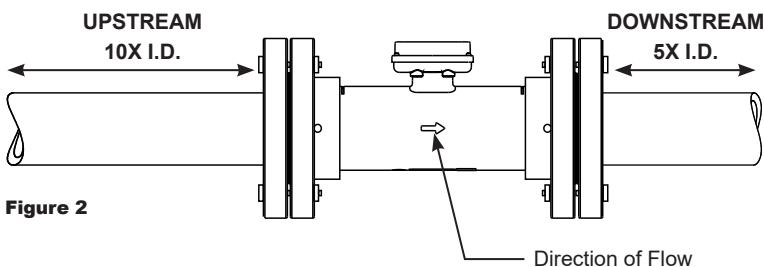

Figure 2

INSTALLATION (CONTINUED)**Connections (continued)**

5. For ANSI or DIN Flange Fittings - Customer to provide:
 - Ring Gaskets or Full-Face Gaskets approved for use with type flange installed (ANSI or DIN) and the fluid being monitored (2 required).
 - 5/8-inch bolts and nuts for ANSI flanges. Four per side for 3-inch meters; eight per side for 4-inch meters.
 - 16 mm bolts and nuts for DIN flanges. Eight per side for 3-inch and 4-inch meters.
 - Torque bolts using a star pattern to 25 ft-lbs (33.8 N·m). Supplied flanges are two-piece Van Stone style and allow the meter to be oriented regardless of the mating flanges position.

For best results, always verify accuracy before use.

CAUTION

Blowing compressed air through the turbine assembly could damage the rotor.

CAUTION

Do not allow liquids to dry inside the turbine.

CAUTION

Handle the rotor carefully. Small scratches or nicks can affect accuracy.

OPERATION / CALIBRATION

Verify Meter Accuracy

Before using, check the meter's accuracy and verify calibration.

1. Make sure there is no air in the system by starting the flow until it runs steadily. Then, stop or divert the flow using a valve or nozzle.
2. Meter an exact known volume into an accurate container. For best results, meter with one continuous full stream.
3. Check the volume against the display or recording equipment. If the amount metered is accurate, further calibration is not necessary. If not, refer to the Q9 Owner's Manual (Non-Agency) Field Calibration Section for further instructions (see below).

NOTE: Make sure you meet the meter's minimum flowrate requirements:

TM Series Meter Minimum Flowrate	
TM30 - 3 inch	30 GPM (113.6 L/min)
TM40 - 4 inch	40 GPM (151.4 L/min)

You can download the Q9 Owner's Manual (Non-Agency) here:



or visit FLOMECmeters.com to download owner's manuals and other technical documents.

MAINTENANCE

NOTE: Proper handling and care will extend the life and service of the meter

Turbine Rotor

The meter is virtually maintenance-free. However, it is important the rotor moves freely. Keep the meter clean and free of contaminants.

The rotor can be removed for cleaning and inspection. Begin by unscrewing the nose cone from the outlet end of the meter. A 1/4" square socket extension can be used. Remove the lock and flat thrust washers. Rotor can then be removed from shaft. Note orientation because rotor is not bi-directional. Remove debris or deposits using soft brush or small probe. Reassemble in reverse order.

▲ CAUTION

Blowing compressed air through the turbine assembly could damage the rotor.

▲ CAUTION

Do not allow liquids to dry inside the turbine.

▲ CAUTION

Handle the rotor carefully. Small scratches or nicks can affect accuracy.

PARTS / ACCESSORIES LIST FOR TM SERIES METERS

Part Number	Description
12517601	Gasket
125175-11	Computer mount assembly
901002-52	Seal
113435-10	Conditioned Signal Module (GEN 2)
125060-10	Pulse Access/External Power/Scaled Module (GEN 2)
125100-10	4-20mA Module

PARTS & SERVICE

For warranty consideration, parts, or other service information, please contact your local distributor. If you need further assistance, contact the GPI Product Support Department in Wichita, Kansas, during normal business hours.

A toll free number is provided for your convenience.

1-888-996-3837

To obtain prompt, efficient service, always be prepared with the following information:

- The model number of your meter.
- The serial number or manufacturing date code of your meter.
- Part descriptions and numbers.

For warranty work, always be prepared with your original sales slip or other evidence of purchase date.

IMPORTANT: Please contact GPI before returning any parts. It may be possible to diagnose the trouble and identify needed parts in a telephone call.

CAUTION

Do not return this product without prior approval from the GPI Product Support Department. Due to strict government regulations, GPI cannot accept parts unless they have been drained and cleaned.

WEEE DIRECTIVE



The Waste Electrical and Electronic Equipment (WEEE) directive (2002/96/EC) was approved by the European Parliament and the Council of the European Union in 2003. This symbol

indicates that this product contains electrical and electronic equipment that may include batteries, printed circuit boards, liquid crystal displays or other components that may be subject to local disposal regulations at your location. Please understand those regulations and dispose of this product in a responsible manner.

ROHS COMPLIANT (2011/65/EU)

This product is in compliance with the RoHS Directive of the European Parliament and of the Council on the Restriction of the Use of Certain Hazardous Substances in Electrical and Electronic Equipment.

Environmental Rating: IP65



FLOMEC® TWO-YEAR LIMITED WARRANTY

Great Plains Industries, Inc. 5252 E. 36th Street North, Wichita, KS USA 67220-3205, hereby provides a limited warranty against defects in material and workmanship on all products manufactured by Great Plains Industries, Inc. This product includes a 2 year warranty. Manufacturer's sole obligation under the foregoing warranties will be limited to either, at Manufacturer's option, replacing or repairing defective Goods (subject to limitations hereinafter provided) or refunding the purchase price for such Goods theretofore paid by the Buyer, and Buyer's exclusive remedy for breach of any such warranties will be enforcement of such obligations of Manufacturer. The warranty shall extend to the purchaser of this product and to any person to whom such product is transferred during the warranty period.

The warranty period shall begin on the date of manufacture or on the date of purchase with an original sales receipt. This warranty shall not apply if:

- A. the product has been altered or modified outside the warrantor's duly appointed representative;

- B. the product has been subjected to neglect, misuse, abuse or damage or has been installed or operated other than in accordance with the manufacturer's operating instructions.

To make a claim against this warranty, contact the GPI Customer Service Department at

316-686-7361 or 888-996-3837.

Or by mail at:

Great Plains Industries, Inc.

5252 E. 36th St. North

Wichita, KS, USA 67220-3205

The company will step you through a product troubleshooting process to determine appropriate corrective actions.

GREAT PLAINS INDUSTRIES, INC., EXCLUDES LIABILITY UNDER THIS WARRANTY FOR DIRECT, INDIRECT, INCIDENTAL AND CONSEQUENTIAL DAMAGES INCURRED IN THE USE OR LOSS OF USE OF THE PRODUCT WARRANTED HEREUNDER.

The company herewith expressly disclaims any warranty of merchantability or fitness for any particular purpose other than for which it was designed.

This warranty gives you specific rights and you may also have other rights which vary from U.S. state to U.S. state.

Note: In compliance with MAGNUSON MOSS CONSUMER WARRANTY ACT – Part 702 (governs the resale availability of the warranty terms).

IP65



1-800-899-0553